

Applicable Standards:

- STEEL CHECK VALVES, API 594/API 6D
- STEEL CHECK VALVES, ISO 14313
- STEEL VALVES, ASME B16.34
- FACE TO FACE, ASME B16.10
- END FLANGES, ASME B16.5
- INSPECTION AND TEST, API 598/API 6D

Design descriptions:

- ONE PIECE BODY
- BUTTERFLY SWING TYPE
- DUAL-PLATE DISC, LONG-PATTERN
- RENEWABLE SPLIT DISC
- HORIZONTAL OR VERTICAL SERVICE
- WAFER ENDS
- AVAILABLE WITH FLANGED ENDS

Materials of parts

No	Part Name	Carbon Steel	ASTM Materials 18Cr-9NiMo	Low Temperature Carbon Steel
1	Body	A216-WCB	A351-CF8M	A352-LCB
2	Plate	A216-WCB+CR13	A351-CF8M+HF	A350-LCB+CR13
3	Stop Pin	A276-420	A276-304	A276-420
4	Back Spring	A313-304	A313-316	A313-304
5	Hinge Pin	A276-420	A276-304	A276-420
6	Eyebolt ²⁾	Carbon Steel		

Note: 1) NPS 8" & larger.

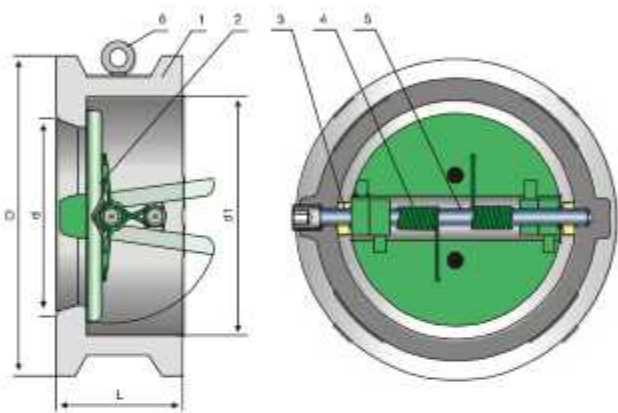

Dimensional datas of ANSI Class 150Lb

NPS DN	2	2½	3	4	6	8	10	12	14	16	18	20	24	in
	50	65	80	100	150	200	250	300	350	400	450	500	600	mm
L	2.38	2.62	2.88	2.88	3.88	5.00	5.75	7.12	7.25	7.50	8.00	8.62	8.75	in
	60	67	73	73	98	127	146	181	184	191	203	219	222	mm
D	4.00	4.88	5.38	6.75	8.62	10.88	13.25	16.00	17.62	20.12	21.50	23.75	28.12	in
	103	122	135	173	220	277	337	407	448	512	547	604	715	mm
d	2.00	2.50	3.25	4.00	6.00	8.00	10.00	12.00	13.75	15.75	17.75	19.75	23.62	in
	51	65	80	102	152	203	254	305	350	400	450	500	600	mm
D1	2.25	2.88	3.50	4.25	6.25	8.25	10.50	12.12	14.00	16.00	18.00	19.88	23.75	in
	56	73	88	108	160	210	266	310	355	405	455	505	605	mm
WT	2	3	4	6	13	25	39	54	80	117	138	163	331	kg

Dimensional datas of ANSI Class 300Lb

NPS DN	2	2½	3	4	6	8	10	12	14	16	18	20	24	in
	50	65	80	100	150	200	250	300	350	400	450	500	600	mm
L	2.38	2.62	2.88	2.88	3.88	5.00	5.75	7.12	8.75	9.12	10.38	11.50	12.50	in
	60	67	73	73	98	127	146	181	222	232	264	292	318	mm
D	4.25	5.00	5.75	7.00	9.88	12.00	14.12	16.50	19.00	21.12	23.38	25.62	30.38	in
	110	128	147	179	249	305	359	420	483	537	594	652	772	mm
d	2.00	2.50	3.00	4.00	6.00	8.00	10.00	12.00	14.00	16.00	18.00	20.00	24.00	in
	51	65	80	102	152	8.25	254	305	350	400	450	500	600	mm
D1	2.25	2.88	3.50	4.25	6.38	203	10.50	12.25	14.00	16.00	18.00	20.00	24.00	in
	58	73	88	108	160	210	266	310	355	405	455	505	608	mm
WT	3	4	6	8	18	31	51	77	117	190	200	265	410	kg

Applicable Standards:

- STEEL CHECK VALVES, API 594/API 6D
- STEEL CHECK VALVES, ISO 14313
- STEEL VALVES, ASME B16.34
- FACE TO FACE, ASME B16.10
- END FLANGES, ASME B16.5
- INSPECTION AND TEST, API 598/API 6D

Design descriptions:

- ONE PIECE BODY
- BUTTERFLY SWING TYPE
- DUAL-PLATE DISC, LONG-PATTERN
- RENEWABLE SPLIT DISC
- HORIZONTAL OR VERTICAL SERVICE
- WAFER ENDS
- AVAILABLE WITH FLANGED ENDS

Materials of parts

No	Part Name	Carbon Steel	ASTM Materials 18Cr-9NiMo	Low Temperature Carbon Steel
1	Body	A216-WCB	A351-CF8M	A352-LCB
2	Plate	A216-WCB+CR13	A351-CF8M+HF	A350-LCB+CR13
3	Stop Pin	A276-420	A276-304	A276-420
4	Back Spring	A313-304	A313-316	A313-304
5	Hinge Pin	A276-420	A276-304	A276-420
6	Eyebolt ²⁾	Carbon Steel		

Note: 1) NPS 8" & larger.

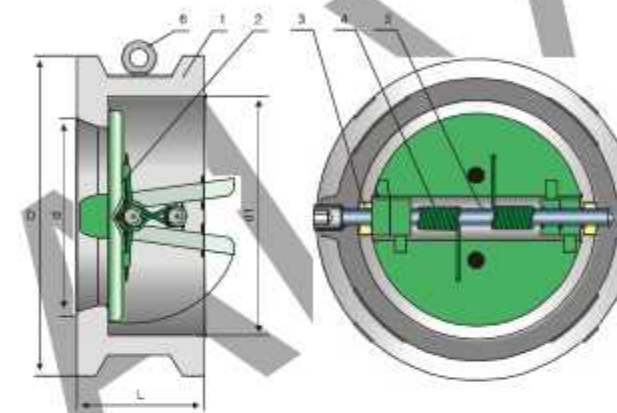

Dimensional datas of ANSI Class 600Lb

NPS DN	2	2½	3	4	6	8	10	12	14	16	in
	50	65	80	100	150	200	250	300	350	400	mm
L	2.38	2.62	2.88	3.12	5.38	6.50	8.38	9.00	10.75	12.00	in
	60	67	73	79	137	165	213	229	273	305	mm
D	4.38	5.00	5.75	7.50	10.38	12.50	15.62	17.88	19.25	22.12	in
	110	128	147	191	264	318	398	455	490	562	mm
d	2.00	2.50	3.00	4.00	6.00	7.88	9.88	12.00	13.25	15.25	in
	51	65	80	102	152	200	250	305	337	387	mm
D1	2.25	2.88	3.50	4.25	6.38	8.38	10.50	12.25	14.00	15.75	in
	58	73	88	108	162	212	266	312	355	400	mm
WT	4	5	8	11	26	55	95	140	223	360	kg

Dimensional datas of ANSI Class 900Lb

NPS DN	2	2½	3	4	6	8	10	12	14	16	in
	50	65	80	100	150	200	250	300	350	400	mm
L	2.75	3.25	3.25	4.00	6.25	8.12	9.50	11.50	-	-	in
	70	83	83	102	159	206	241	292	-	-	mm
D	5.50	6.38	6.50	8.00	11.25	14.00	17.00	19.50	-	-	in
	140	162	165	204	286	356	432	495	-	-	mm
d	2.00	2.50	3.00	4.00	6.00	7.88	9.88	12.00	-	-	in
	51	62	80	102	152	200	250	305	-	-	mm
D1	2.25	2.88	3.50	4.25	6.38	8.38	10.50	12.25	-	-	in
	58	73	88	108	162	212	266	312	-	-	mm
WT	8	11	14	20	42	84	145	220	-	-	kg